

PP P.D9

BASE STONE = CRUSHED STONE PROCESSED FOR SYNTHETIC TURF SYSTEM SHALL BE PROCESSED FROM A STONE QUARRY, WASHED, GRADED, FREE OF ORGANIC MATERIALS.

FINISHING STONE = CRUSHED STONE PROCESSED FOR SYNTHETIC TURF SYSTEM SHALL BE DURABLE STONE PROCESSED FROM A STONE QUARRY, WASHED, GRADED, FREE OF ORGANIC MATERIALS.

GRADATION IS AS FOLLOWS:

GRADATION IS AS FOLLOWS:

U.S. SIEVE NO.	% PASSING BY WEIGHT
1"	100
3/4"	90-100
1/2"	30-60
3/8"	25-45
#4	5-30
#10	0-10

U.S. SIEVE NO.	% PASSING BY WEIGHT
1/2"	100
3/8"	85-100
#8	35-75
#16	10-55
#30	0-40
#50/60	0-15
#100	0-8
#200	0-2

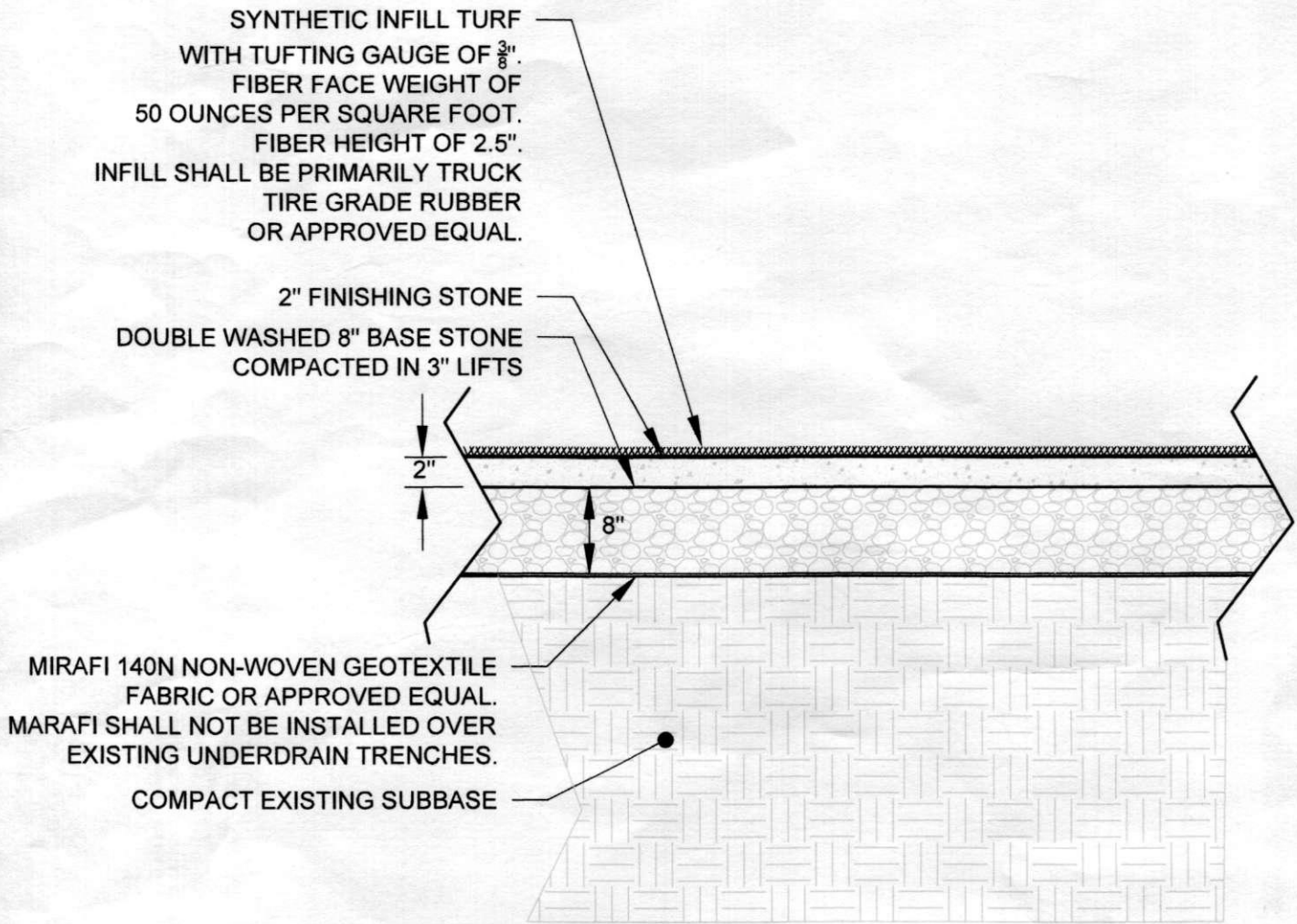

NOTES:

1. SYNTHETIC TURF AND INFILL MATERIAL SHALL MEET THE STANDARDS SET FORTH IN THE CONSUMER PRODUCT SAFETY AND IMPROVEMENT ACT.
2. EACH PORTION OF THE INFILL TURF SYSTEM SHALL MEET THE PROP 65 LEAD CONTENT REQUIREMENT IN CALIFORNIA.

PP P.D-9

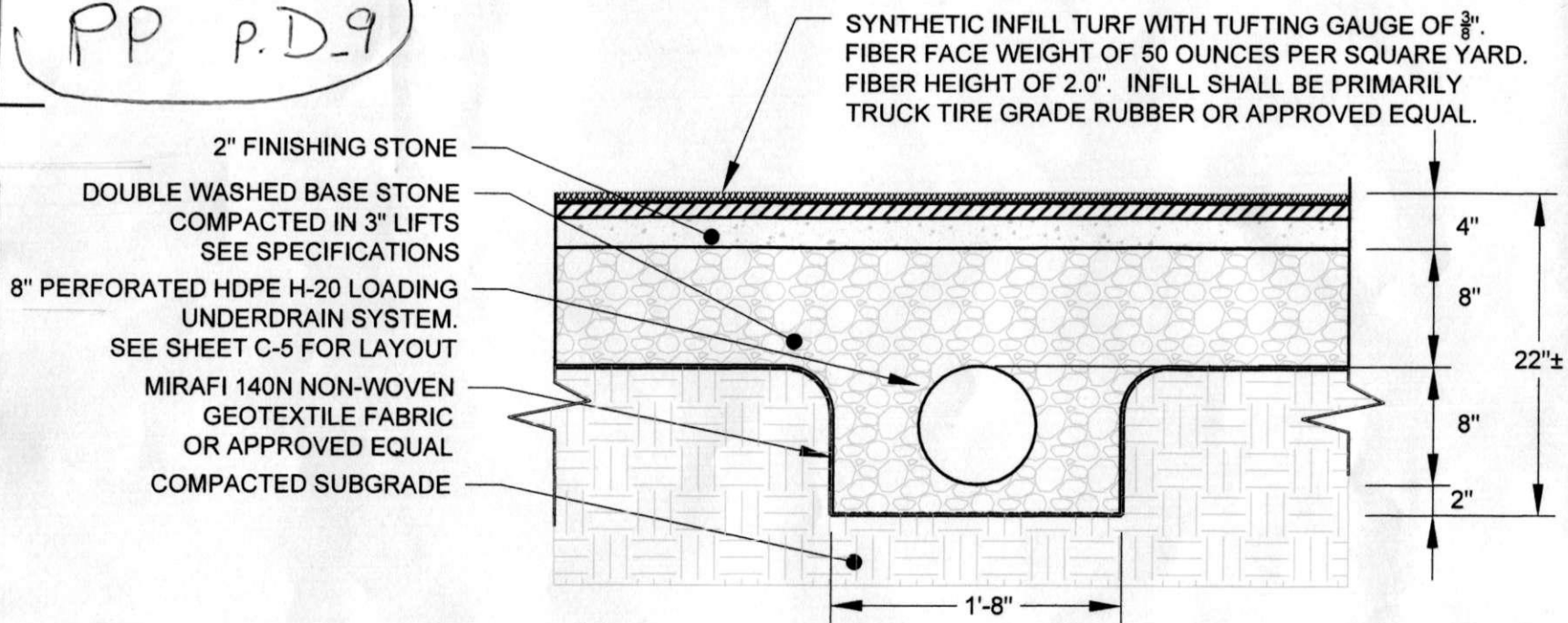

D FIELD UNDERDRAIN SYSTEM
NOT TO SCALE